



# WATER PURIFICATION WELL-REGENERATION

## WATER PURIFICATION

### LifeTech: Sustainable Solutions for an Essential Resource

LifeTech is a values-driven organization dedicated to transforming the utilization of one of our most vital resources –water. We prioritize ensuring easy access to clean drinking water and implementing efficient wastewater treatment solutions.

## OUR PHILOSOPHY

We assert that every individual is entitled to clean water, and we depend on innovative technologies to actualize this vision. Through sustainable solutions and a steadfast commitment to environmental stewardship and social responsibility, we contribute to a brighter future for all. With LifeTech, we are collectively advancing towards responsible and sustainable water utilization.



**LifeTech**  
WATERSOLUTIONS



# GERMAN MADE IN GERMANY ENGINEERING

Years of development by our German engineering team are now evident in this distinctive and sophisticated technology. It eliminates and inactivates organic pollutants, including viruses, bacteria, and pharmaceutical residues such as antibiotics and hormones. The elevated temperatures produced by cavitation enable us to diminish minute inorganic particles, such as microplastics.

Through the implementation of innovative processes, we ensure not only a high standard of water purity but also make a significant contribution to the protection of the environment and human health. Our systems operate without the use of any chemicals! In this manner, we establish a solid foundation for sustainable water utilization.

## SUSTAINABLE

OUR INNOVATIVE AND PATENTED TECHNOLOGY IS BASED ON

- HIGH-FREQUENCY ULTRASOUND
- MODIFIED UV UNITS
- Ozone Systems



Our systems are entirely environmentally sustainable. We refrain from utilizing any harmful chemicals or substances for water treatment or well regeneration.

**The following institutions and universities have, among others, evaluated and validated the effectiveness and efficiency of our devices:**

- University of Prague (Czech Republic)
- KIT - Karlsruhe Institute of Technology (Germany)
- THD - Technische Universität Dresden (Germany)
- University of Mainz (Germany)
- University of Jena (Germany)



# TAP WATER & WASTEWATER

We provide customized solutions for purifying your tap water and managing wastewater.

Our systems can also be utilized for the effective cleaning of lakes and rivers.

Furthermore, we facilitate the treatment of seawater. By incorporating our advanced technology into saltwater desalination facilities, wear and vulnerability to failure (biofilms and deposits) are markedly diminished, thereby enhancing the longevity and efficiency of the plants.

## A TECHNOLOGICAL ADVANCEMENT NUMEROUS ADVANTAGES

- More economical than traditional methods
- Eco-friendly - devoid of any chemicals
- Reduces substantial energy expenses
- for all wells and water connections
- inactivation of dubious ingredients
- Safeguards the well structure and piping.

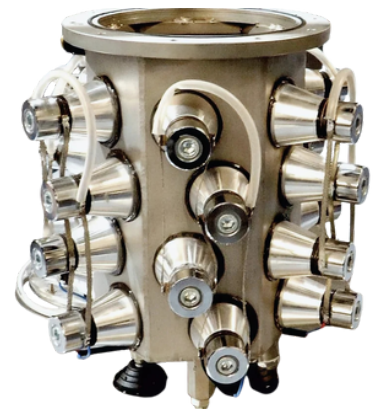

## AREAS OF APPLICATION ENCOMPASS

- **Cruise ships:** Guaranteeing the quality of tap water onboard and the elimination of pollutants in wastewater.
- **Agriculture:** Water management for agricultural operations and irrigation systems.
- **Wastewater treatment facilities:** effective wastewater treatment and purification.
- **New construction initiatives:** Ensuring access to clean water in expanding urban regions.
- **Textile industry:** management of process water and wastewater treatment.
- **Clinics:** Impeccably hygienic water for medical facilities.
- **Urban groundwater wells:** safeguarding and purification of potable water sources.
- **War zones:** Mobile water supply in conflict regions.
- **Environmental Disasters:** Prompt and Dependable Water Treatment Following Natural Catastrophes.
- **Hotel amenities:** Potable drinking water and service water.

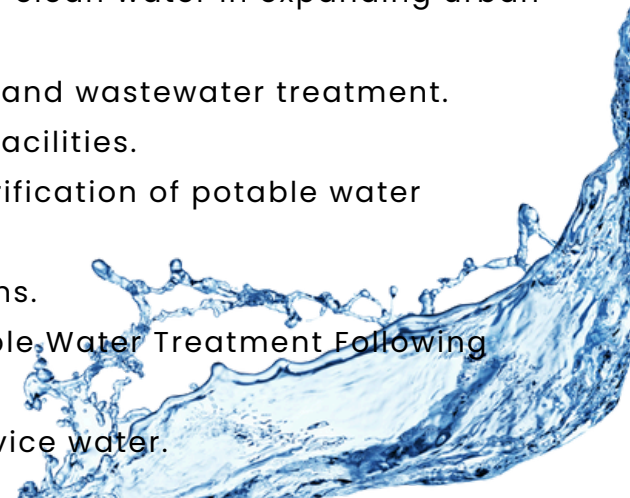

# PLANNING YOUR SYSTEM



## **Customized to your specifications**

We create customized systems specifically designed to meet your unique needs. In addition to our standard models, we can accommodate all requirements, irrespective of project size. Our planning team transforms your visions into reality.

This encompasses a thorough analysis of your current system and water quality. We also provide extensive service and maintenance for the equipment, although such interventions are infrequently necessary. Our objective is to guarantee that your systems consistently function efficiently and reliably.

# INSTALLATION

## **Worldwide installation by our specialists**

Our modules can be installed globally by our skilled technicians. The complete installation process is streamlined and typically requires only a brief duration.

## **Professional and straightforward**

We assure a professional and straightforward installation, enabling you to swiftly reap the benefits of our technologies. Our team is readily available to assist and ensure a seamless commissioning process.

**Our devices can seamlessly integrate into any existing system.**

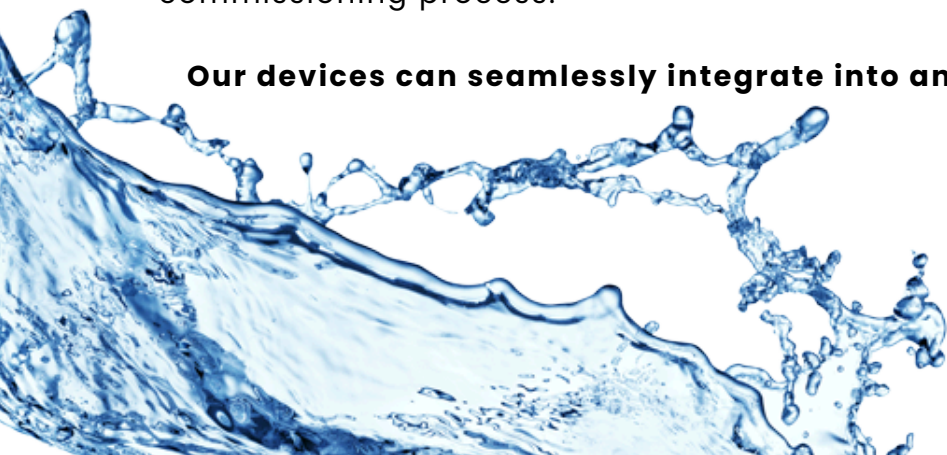



# FLOWCHART (PFD)

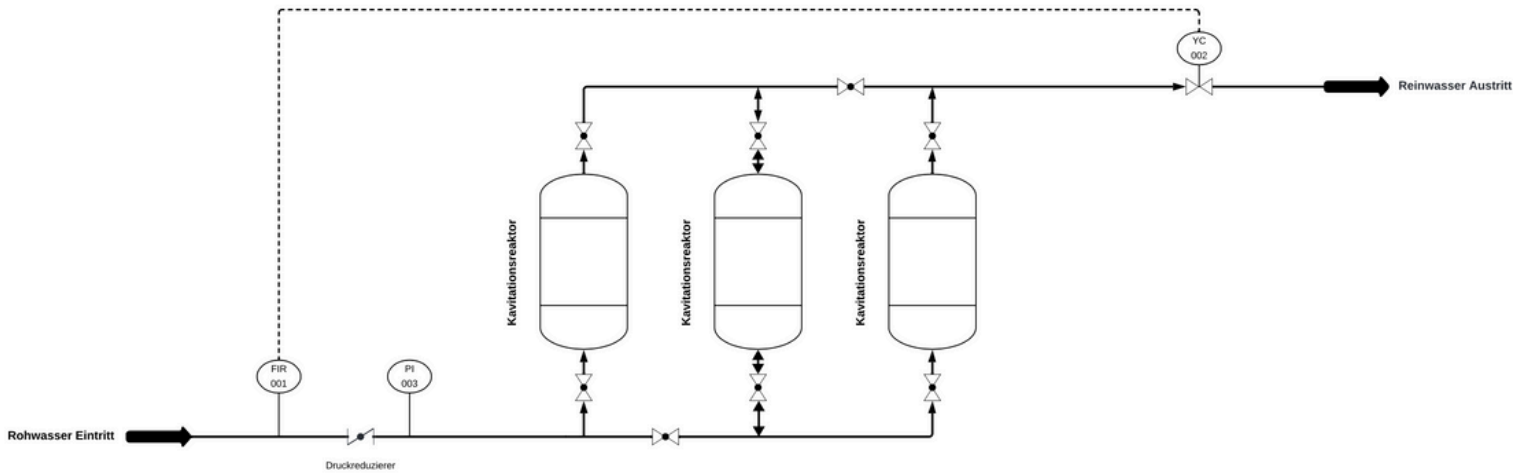

To treat the introduced water, a microbubble or cavitation cloud is generated within the ultrasonic reactor. Our proprietary technology effectively inactivates organic pollutants, including viruses, hormones, and pharmaceutical residues. Additionally, the significant temperature differentials (reaching up to 5,000 K) facilitate the conversion of microplastic particles into carbon.

## The ultrasound systems can be enhanced by us with the following modules customized for the process.

- Energy-efficient LED UV-C lamps featuring an extended service life.
- ozone enrichment system
- desalination facilities
- Pre- and post-filtration for solid constituents
- Modules for revitalizing potable water

# TESTED

The following institutions and universities have, among others, evaluated and validated the effectiveness and efficiency of our devices:

- University of Prague (Czech Republic)
- KIT - Karlsruhe Institute of Technology (Germany)
- THD - Technische Universität Dresden (Germany)
- University of Mainz (Germany)
- University of Jena (Germany)



# ULTRASOUND PROBE

## FOR THE RESTORATION OF GROUNDWATER WELLS

Our specially designed probe for cleaning groundwater wells is unparalleled globally. It effectively cleans deep within the filter gravel without employing chemicals or high-pressure equipment. This innovative approach allows for the preservation of the well structure and significantly prolongs its service life.

The probe operates at high ultrasonic frequencies beginning at 20,000 Hz and can efficiently clean wells with a diameter of up to 600 mm and a depth of up to 200 meters. Utilizing the probe in the shaft just once also results in significant time savings.



-240 cm / approximately 80 kg-

Designed,  
developed and  
made in Germany



No chemicals are necessary, and the probe is entirely environmentally friendly. This eco-conscious technology guarantees a gentle cleaning process that safeguards both the well structure and the surrounding environment.

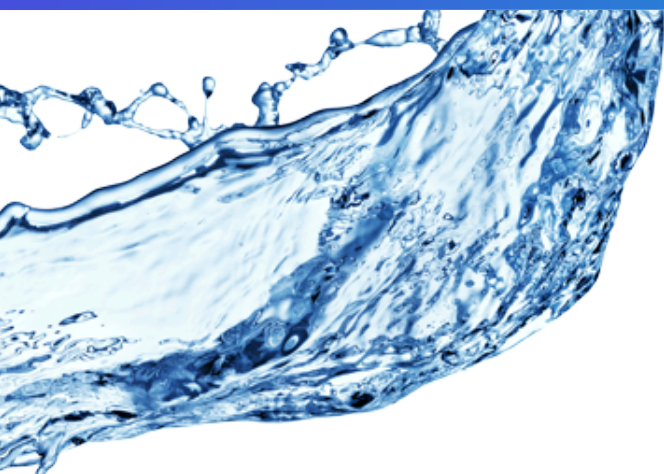

### CLEAR ADVANTAGES

- Eco-friendly and free from chemicals
- Protect the well shaft
- More economical than traditional methods
- Increases the lifespan of wells
- Manufactured in Germany

# ALLOW US TO PROVIDE GUIDANCE.

We would be pleased to create a customized concept for you.



[LifeTech-Watersolutions.com](https://www.LifeTech-Watersolutions.com)



[info@LifeTech-Watersolutions.com](mailto:info@LifeTech-Watersolutions.com)



+49 (0) 2303 9379820

“We bear the primary responsibility for the condition of the Earth on a global scale. We are the foremost contributors to the depletion of the planet's resources and the primary agents of Earth's destruction.”

**Jacques-Yves Cousteau**

marine scientists and ecological advocates



**LifeTech**  
WATERSOLUTIONS

